

Robot Phonotaxis in the Wild: a Biologically Inspired Approach to Outdoor Sound Localization

A.D. Horchler* R.E. Reeve** B.H. Webb** R.D. Quinn*

* Department of Mechanical & Aerospace Engineering
Case Western Reserve University
Room 418, Cleveland, OH 44106-7222, USA
horchler@cwru.edu, rdq@cwru.edu

**Department of Psychology
Stirling University
Room 3B106, Stirling, Scotland FK9 4LA, UK
richardr@ini.phys.ethz.ch, b.h.webb@stir.ac.uk

Abstract

Cricket phonotaxis (sound localization behavior) was implemented on an autonomous outdoor robot platform inspired by cockroach locomotion. This required the integration of a novel robot morphology – Whegs – with a biologically-based auditory processing circuit and neural control system, as well as interfacing this to a new tracking device and software architecture for running robot experiments. In repeated tests, the robot is shown to be capable of tracking towards a simulated male cricket song over natural terrain. We discuss what was learned about the auditory control circuit dealing with the outdoor sound stimulus, the need for a motor feedback mechanism to better regulate the drive signal, and plans for future work incorporating additional sensory systems on this platform.

1. Introduction

A fast-growing area in robotics involves interaction with biology. Biology may provide ideas to make robot behavior more successful and adaptive, including design of sensor hardware, vehicle morphology, and control mechanisms based upon neural circuitry. At the same time, robots can be used as hardware models for embedding and testing biological hypotheses [30]. Advances in biology, particularly in the study of insect behavior, are making this approach more and more plausible and productive. A number of “invertebrate robot” systems have been built over the past fifteen years, including fly-vision inspired navigation devices by Francheschini [6] and Srinivasan et al. [26], polarization-compass and landmark recognition systems based on the desert ant by Lambrinos et al. [12], and chemo-sensing and biomimetic “robo-lobsters” by Grasso et al. [7] and Ayers et al. [1], respectively. Building upon this success, even more advanced robot capabilities can be realized by escalating this approach.

In previous work, Webb and Reeve have investigated, in a laboratory setting, robot models of the sound localization behavior of female crickets. Females are able to find males by tracking towards the characteristic calling song (see review in [17]). They have shown that the unique cricket ear design [14] can be copied to produce a good directional sensor [29], [13], that a relatively simple neural network can reproduce many of the characteristics of the animal’s ability to recognize and localize sound [32], [21], and that this auditory behavior can be combined with visual stabilization to obtain a reliable response when the robot is subject to systematic or random disturbances [31], [21]. Here, we explore the efficacy of this system when faced with more realistic environmental conditions, e.g. outdoor sound propagation and the problems of negotiating the corresponding terrain. This requires a robot morphology that is able to deal with more rugged terrain than the wheeled robots (Koala [10] and Khepera [11]) used previously. It is desirable to have such a platform resemble the locomotion capability of the cricket, as this requires us to consider the motor output that the cricket’s neural circuit must provide. However, there are as yet no autonomous robots capable of close and reliable emulation of cricket walking.

Quinn et al. have developed a number of robots based on extensive consideration of the mechanics of six-legged walking in cockroaches [5], [16], [2], and crickets [4], [3]. Some of these robots comprise highly detailed copies of insect morphology, and also require the development of new actuation and control technologies. Robots developed using this direct approach of intelligent biological inspiration [22] have helped elucidate many principles of locomotion, but are as of yet not capable of autonomous operation. Hence, Quinn et al. have recently developed a parallel strategy that aims to extract some of the basic biological principles and use them to construct simpler vehicles using current technologies [19], [18]. This abstracted approach to intelligent biological inspiration has led to the successful series of Whegs robots (© Quinn).

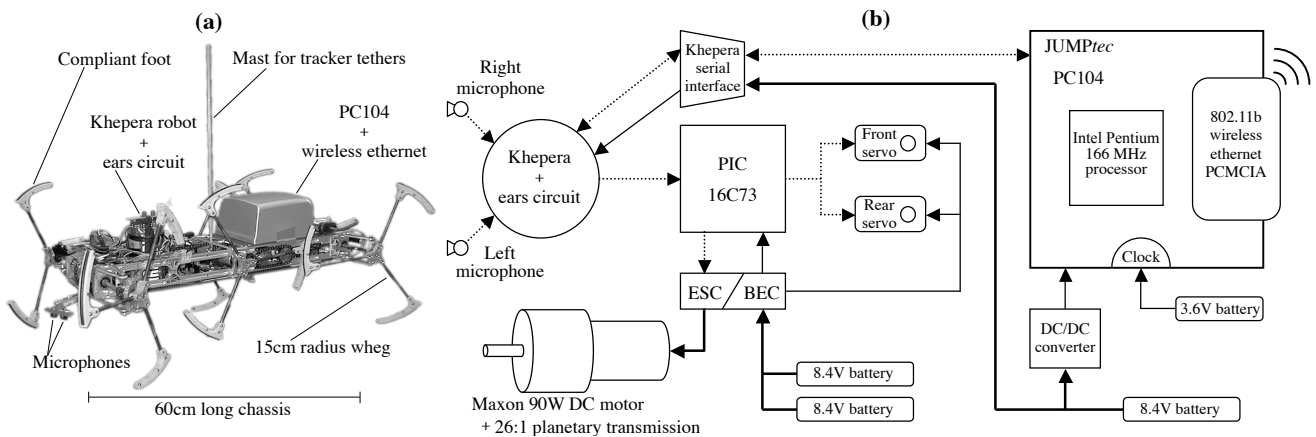

Figure 1. The Whegs ASP **a)** robot and **b)** hardware and electronics used in outdoor phonotaxis experiments.

A cockroach has six legs, which support and move its body. It typically walks and runs in a tripod gait where the front and rear legs on one side of the body move in phase with the middle leg on the other side. The front legs swing head-high during normal walking so that many obstacles can be surmounted without a change in gait. However, when large barriers are encountered, the animal’s gait changes and its contralateral legs move in phase. The cockroach also pitches its body up prior to climbing large obstacles and uses its body joints to avoid high centering during a climb [28]. The cockroach turns by generating asymmetrical motor activity in legs on either side of its body as they extend during stance [27]. These actions redirect ground reaction forces so as to alter the animal’s heading [9].

Current Whegs robots have a single drive motor, yet move quickly and climb obstacles. They do so by employing all of the aforementioned cockroach strategies, except body flexion. Despite its simplicity, the vehicle is still highly capable because its locomotion controller is embedded in passive mechanical systems. The two most important of these components are the three-spoked appendages and the passively compliant drive train mechanisms, that together form a “wheg” (patent pending).

The Whegs robots thus provide an “appropriately lifelike” yet robust platform on which to test the outdoor

behavior of the cricket-based control system. In addition, the whegs technology had not previously been tested under autonomous control, so this work evaluates its suitability as an autonomous robot platform that bridges the gap from wheels to legs. This paper describes the implementation of cricket phonotaxis on a Whegs robot, termed Whegs Autonomous Sensor Platform (Whegs ASP). In Section 2, we give details of the robot’s construction, the sensory and neural circuitry used to generate localization behavior, and the customized tracking system we have built for testing the behavior. Section 3 describes our results and Section 4 provides discussion and future plans.

2. Methods

Implementing cricket phonotaxis on a Whegs robot required the integration of a number of different hardware and software elements. Figure 1 shows the main elements of the system, which are described in more detail below. A Khepera robot with a customized electronic circuit to process cricket sound was mounted on the newly designed Whegs ASP base (see Section 2.1). The “ears,” a pair of miniature microphones, were mounted to a four-bar mechanism attached to the front steering, allowing them to pivot with the front whegs.

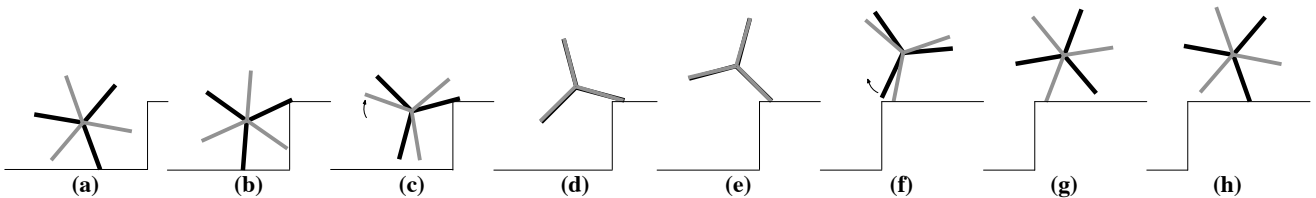

Figure 2. Illustration of the Whegs concept: **a)** the two front whegs of the robot approach an obstacle; **b)** the far (black) wheg makes contact first, and **c)** while the far wheg is slowed, passive torsional compliance in the drive train allows the near (gray) wheg to rotate into phase with the far wheg; **d)** once in phase, the two whegs can **e)** propel the front of the robot over the obstacle; **f)** atop the obstacle the two whegs separate and **g)** spring back to their **h)** prior configuration.

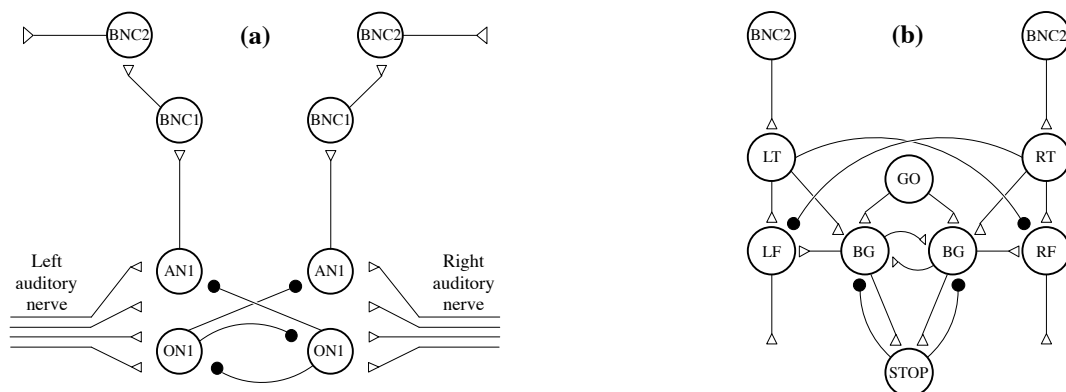

Figure 3. Neural circuits based on cricket neurophysiology, for **a)** auditory processing and **b)** motor control.

This mechanism allows the microphones to point in the direction of a turn, mimicking the way cricket’s ears, which are located on their front legs, move during turning. Auditory input was transferred via a serial line, using a spike encoding, to a PC104 processor running a neural simulator under Linux. A neural network closely based on cricket neurophysiology determined the response to the sound signal (see Section 2.2). The motor output was also encoded as a spike train and interfaced to the Whegs steering servos and Astro-Flight electronic speed controller (ESC) via a programmable PIC. The robot carries the entire processing system, including power supply, and operates autonomously except for “start” and “stop” signals and configuration commands between experiments. To communicate with a laptop, a PCMCIA 802.11b wireless ethernet card is installed in the PC104 onboard the robot. The laptop also runs a tracking system based on triangulation using retractable tethers (see Section 2.3).

2.1. The Whegs ASP Robot

The Whegs ASP design provides increased robustness, power, and mobility over the original Whegs I vehicle [19], [18]. It is based upon a lightweight 60cm long by 15cm wide chassis constructed from 6061-T6 aluminum. The drive train is powered by a single 90W Maxon RE35 DC motor mounted to a 26:1 Maxon GP42C planetary transmission. Front and rear rack-and-pinion steering is activated with two electrically coupled Futaba servomotors. Two 3000mAh NiMH battery packs connected in parallel provide 8.4V to the drive motor via the ESC and 5V to the servos via a battery eliminator circuit (BEC) contained within the ESC. A third electrically isolated 8.4V battery pack was used to power the PC104 and Khepera during experiments.

Whegs ASP has six 15cm-radius three-spoke whegs, each of which is arranged 60 degrees out of phase from adjacent whegs, allowing the robot to move with a nominal tripod gait. The torque delivered to each wheg

passes through a torsionally compliant mechanism that permits a wheg to comply if an obstacle is encountered, thus moving into phase with the contralateral wheg. Figure 2 illustrates this concept for the case of the front whegs climbing a step. Additionally, large compliant “feet” at the tip of each spoke cushion and smooth the robot’s vertical motion without seriously compromising its climbing ability. These feet are designed to have good traction on a variety of surfaces, but other foot designs can easily be attached.

Whegs ASP can attain speeds of up to 2 body-lengths per second (1.2m/sec) at 8.4V. Connecting the battery packs in series, to provide 16.8V, doubles this speed. The three-spoke design and torsional compliance in the drive train allow it to climb up and down standard stairs and inclines and easily traverse most terrains, such as asphalt, grass, mud, gravel, and light brush. The robot has a turning radius of 1.5 body-lengths (0.9m) and weighs 6.0kg with batteries but no payload. For the experiments described in section 3, approximately 1.2kg of payload was carried. Carrying this payload, battery life is over one hour with the robot moving continuously on a variety of terrains.

2.2. The Sensors and Neural Controller

The robot uses a custom built auditory sensor circuit based on the ear morphology of the cricket. The two microphones have a separation of 18mm, and the input from each is delayed and then subtracted from the other. This effectively performs a phase comparison and provides directional information that is frequency dependent. The separation and delays are tuned to make the directional output best for the typical carrier frequency of cricket song – 4.8kHz. This auditory circuit had been custom-designed to interface to a Khepera robot, and it proved simplest to mount this small robot directly on the Whegs ASP base and use it to do the sensory preprocessing. This consisted of converting the signal amplitudes to Poisson spike trains, with

programmable threshold and saturation levels, which are used as inputs to the neural simulator running on the PC104.

Details of this simulator are provided in [21]. The main features are that it encodes realistic neural dynamics at the single compartment level (an integrate and fire neural model with conductance-based synapses), and is capable of running in real time (500Hz update rate) on the PC104. Using this simulator, we have designed a neural circuit based on the physiological mechanisms known to underlie phonotaxis behavior in the cricket, shown in Figure 3a. The spiking input from the auditory preprocessing excites one pair of auditory interneurons (ON) and one pair of ascending neurons (AN). The first (mutually inhibitory) pair performs cross-inhibition of the other to sharpen the directionality of the signal; the second pair conveys this signal to “brain” neurons (BN1 and BN2) that use dynamic synapse properties to filter the song for the appropriate temporal pattern. The filtered output indicates, through the activity of the left and right brain neurons, if a male of the correct species is calling from the left or the right. Therefore, the BN2 output needs to connect to the motor control neurons in order to cause a turn in the direction from which the louder and/or clearer song can be heard.

The motor control circuit (Fig. 3b) is based upon a “burst-generator” (BG) consisting of a pair of neurons coupled by mutual excitation, so that sufficient input to either produces continuous spiking of both. This is eventually terminated because the pair also excites a “STOP” neuron that eventually becomes active and inhibits the bursting pair. In theory, a variety of sensory stimuli or internal factors can activate a motor response either directly or via a “GO” neuron, which modulates the sensitivity of the burst pair by low frequency tonic excitation. In the current system, the GO neuron receives a constant input, representing a response to a high ambient light level, so that the robot’s default behavior will be to move around (crickets have a greater tendency to move about when in the light, rather than hidden in the dark).

The two burst-generator neurons (BG) excite, respectively, a “left forward” (LF) and a “right forward” (RF) motor neuron. These normally connect directly to the speed controllers for the independently driven wheels of a Koala or Khepera robot. For Whegs ASP however, both neurons provide excitation for a “forward” signal that controls the drive motor, while LF excites and RF inhibits a signal that controls the position of the servomotors that steer the robot. If LF and RF are balanced, then the robot steers forward, otherwise it turns according to the difference in activity (LF-RF). The output of the brain processing described above affects the robot’s direction via “left turn” (LT) and “right turn”

(RT) neurons that modulate the activity of the LF and RF neurons by appropriate excitation and inhibition.

In addition to modifying the final motor output, we found several other changes were necessary to make this neural circuit – originally developed for an indoor wheeled robot – work on the outdoor Whegs platform. On the input side, we introduced a range fractionation of the auditory nerve (see Fig. 3a) response. For each of the two “auditory nerve” inputs (left and right), there were four pairs of Poisson spiking neurons with differing threshold and saturation levels. This meant the subsequent processing could deal with a larger range of input amplitudes, which was necessary given the substantial attenuation of the sound signal over the distances we wanted to run the robot. The level of mutual inhibition of the ON neurons was also increased. The principal effect of this was to produce a form of gain control. Louder sounds were more likely to activate auditory neurons on both sides so mutual inhibition would reduce the overall response as well as increase the relative difference. Finally, on the output side, we had to increase the time course of the turning response to ensure that the robot would make a large enough steering correction for each spike signaling a turn.

2.3. The Tracker System

The tracking system was originally designed to allow us to track a Koala robot in an arbitrary area, such as various outdoor locations, where a fixed camera or similar system would not be viable. It is based on the principle of triangulation, using retractable lines that tether the robot to fixed points. Based on the performance of the Koala robot, the specification was to be able to reel in these lines at a speed of 30cm/sec within an area of 20 meters square with a measurement accuracy of 1cm. To accomplish this, line tension must be controlled while the length of line paid in and out is measured.

In our design (Fig. 4b), each tether unit consists of thirty meters of 9kg nylon line accommodated on a take-up reel driven by a motor/gearbox combination. The current in the motor, and therefore the torque of the gearbox shaft, are controlled by using a spring-loaded pulley arm attached to a potentiometer. When the line is pulled out, it initially pulls against the spring tension, causing the arm to move, thus reducing the current in the motor via proportional feedback. The line can then be easily pulled out, but always against a necessary amount of tension. This tension prevents the line from coming off the pulleys and keeps it sufficiently tight around the measurement pulley to ensure accuracy.

The length measurement is based on routing the line around a pulley that is fitted to an optical shaft encoder. The encoder output consists of two 90-degree phase-

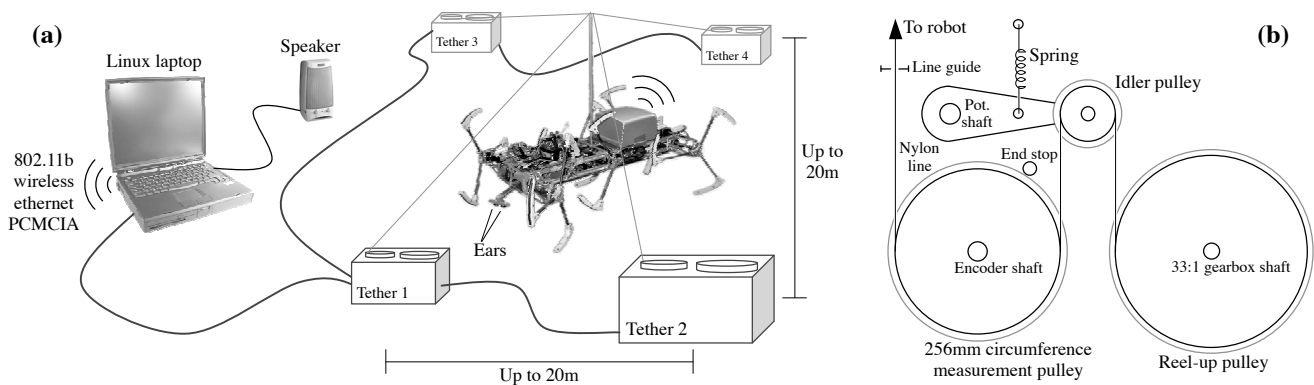

Figure 4. Schematics showing **a)** experimental setup with tethers connected to robot and **b)** layout of tether mechanism.

shifted square waves (quadrature), which output 256 cycles per revolution, providing 1 cycle per millimeter of line movement when used with a 256mm circumference measurement pulley. The encoder outputs are interpreted by a PIC microcontroller, operating as a slave to an external computer, which then outputs the length information onto a 2-wire data bus (I2C).

Each tether box is powered by its own internal 12V battery with onboard charge control circuitry. To increase reliability, the robot is connected to four tether boxes, which are placed in the corners of the area in which the robot is to be run (Fig. 4a). The microcontrollers are connected to a laptop via an I2C-to-parallel adapter. The tracker software running on the laptop calculates and records the robot's position, based on the length information provided by the four tethers. This software is also interfaced (via wireless ethernet) to the neural controller running on the robot so that the robot can be automatically stopped when it reaches a target position, if it moves outside the tracking area, or if the calibration errors become too large. The system is calibrated simply by connecting the four tether endpoints and moving them in turn to each box before connecting them to the robot.

3. Results

We carried out a large number of trials with the robot system described, although the majority of these were concerned with tuning various aspects of the system until a satisfactory performance could be obtained. Our aim was to demonstrate that the robot could perform the basic task of the female cricket: to recognize and track towards a male cricket calling song over a reasonable distance in a natural outdoor environment. Thus, the target was a speaker placed on the ground and connected to a laptop computer, through which we played a simulated male cricket song. This consisted of two "chirps" per second, where each chirp is four cycles of 25Hz square wave amplitude modulation of a 4.8kHz

tone. The sound amplitude was approximately 85dB at the speaker and 65dB at the robot's starting points. The robot was tested on a grass-covered (later frost-covered) area between one of the University of Stirling's buildings and a small lake bordered by trees. For the main results given below, the area used was approximately 10 meters by 7 meters. This area was fairly level but not a smooth lawn. There was little wind. The air temperature was below 0°C.

Figure 5 shows the sound as heard by the robot at different distances, with and without the motors running. At 4 meters, without the motors (Fig. 5a), the basic temporal structure of the sound can be seen, but there is also evident smearing of the sound pattern due to reverberation. When the motors were running, there was a large amount of noise introduced (Fig. 5b). Initially this looked very problematic because, at distances greater than 1-2 meters, the sound pattern could no longer be discerned. Fortunately, the bulk of this interference turned out to be electromagnetic and, by shielding the microphone lead wires from the robot's drive motor, we were able to reduce it to an acceptable level (Fig. 5c). Nevertheless, it was necessary to use range fractionation to minimize the effect of the remaining noise, and this had the effect of reducing the sensitivity to quiet sounds, which limited the distance over which the song could be detected by the robot. Indeed, in the lower graph (Fig. 5d), it can be seen that at 10 meters, the sound signal, though visible when the motors are off, is well below the average noise level from the motors, as depicted in the graph above.

We also had to tune the output of the PIC to ensure that the forward and turning signals were appropriate for driving the robot. It became clear that simple "speed" and "turn" outputs were insufficient, because they did not account for the increased friction encountered during hard turning. Although it is not evident in the track data, the robot tended to stop during turns for several seconds before continuing. This was particularly the case when the robot also had to "drag" the tethers as it moved.

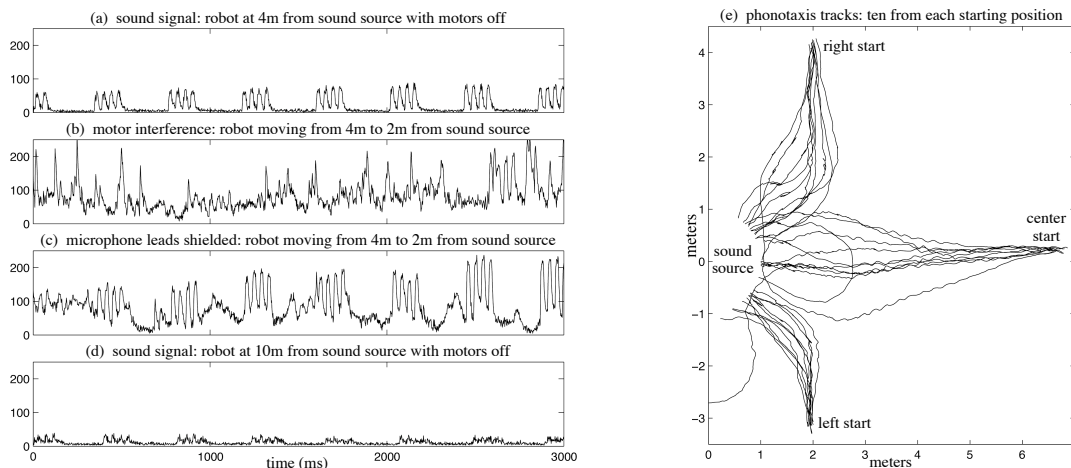

Figure 5. **a) to d)** showing the actual auditory input for outdoor phonotaxis, at different distances and with and without motor interference; **e)** Thirty consecutive outdoor trials, recorded using the tracker, showing the robot approaching the sound source from different directions.

However, increasing the base speed to overcome this would make the robot move too fast when it was going straight so that it would be out of the test area before having a chance to respond to sound. We discuss below how some of these limitations might be overcome in future work.

In Figure 5e, we show a complete set of trials carried out after settling on acceptable parameter settings for auditory thresholds and motor output. The data was produced using the tether system. The robot was run from three different starting locations: 8 meters straight ahead, 3.5 meters to the left, and 4.5 meters to the right of the speaker. We ran 10 trials from each location. It is evident that the robot can successfully and reliably track towards the sound source, with corrective movements being made from a distance of around 3-4 meters. Paths took an average time of 43.8 ± 11.8 seconds from the center, 28.6 ± 8.6 seconds from the right, and 24.0 ± 12.4 seconds from the left. The average speed over the 30 trials was 0.2m/sec.

4. Discussion and Future Work

The robot was successful in localizing and tracking sound in an outdoor environment. The distance over which phonotaxis was performed was more limited than we originally hoped, although still comparable to distances traveled by crickets. The robot was able to cope with sound distortion, including interference from its own motors, and with uneven and slippery terrain. We were able to integrate the many parts of the system – a novel robot morphology based on the cockroach, an auditory sensory circuit based on the cricket, a realistic neural simulator for control, and a new robot tracking mechanism – to run experiments that demonstrated the

capabilities of this biologically based robot.

This was a useful test of the utility of Whegs ASP as a platform for outdoor robotics. It proved capable of carrying the necessary payload to run autonomously, and had good battery life for our purposes. While being a simplified legged robot capable of running over rough terrain, Whegs ASP provided a sufficiently smooth “ride” such that no problems with the mounted electronic equipment were encountered. The main limitation was the lack of any feedback mechanism to allow the controller to regulate the motor signals according to the actual movement of the robot. As the conditions of operation tend to vary, this made it difficult to tune the motor signals. For example, a high input was needed to overcome inertia but this would then make the robot move very fast once it started. As mentioned above, a higher drive torque was also required during turning as compared to forward motion. This limitation can be overcome with the simple addition of an encoder or tachometer connected to the drive motor that would provide the necessary feedback signal.

The turning radius of the robot was rather large relative to the distance over which it had to travel in the sound-localization task. Clearly the robot differs substantially from the insect in this regard, and it also differs sufficiently from the wheeled robots we have previously used to make any direct comparison of the characteristics of the tracks difficult. Because the rate at which sound amplitude decreases over distance is determined by physics, we cannot easily scale the signal to match the size of the robot.

All of this suggests that a smaller robot would be beneficial for more detailed phonotaxis studies. Indeed, the Whegs concept is scalable and smaller versions have been developed [15]. The electronics carried by Whegs

ASP would need to be miniaturized and consolidated in order for a smaller robot to transport them while still remaining autonomous. Analog VLSI circuits are a potential candidate to replace the PC104-based neural simulation [20]. A small robot with cricket-inspired kinematics would exhibit many of the locomotion capabilities of the organism, but producing such a machine requires advancements in actuation, control, and power storage, especially if such a robot is to operate autonomously outdoors.

In the meantime, much further work is possible with the current Whegs ASP robot. We expect it to be capable of producing similar tracking behavior on more irregular terrain, and plan to test this as soon as possible. It should also be possible to have it carry additional sensors, such as the fly-inspired optomotor vision sensor we have used in previous work [31], or some form of antennae to enable it to detect and avoid obstacles. The robot has more space and payload capacity; and it is straightforward to define new inputs into the neural simulator from any sensor system producing an analog or digital signal. This would enable us to investigate issues of sensor integration under very realistic conditions.

The tracker system was successful and will be reused in future outdoor experiments, including those involving rough terrain. A stiffer tether material, a more robust attachment mechanism, and fine-tuning of tension feedback gains would improve the performance of the system when used with the Whegs ASP robot.

With respect to the neural circuit controlling taxis, it was very informative to discover how the processing needed to be modified to run the system outdoors. The robot had to be able to deal with a very substantial change in the amplitude of the signal as it approached the sound. This was dealt with by a combination of range fractionation on the input, and gain control produced by the mutually inhibitory ON neurons, both of which happen in the cricket [8]. Another possible mechanism to consider would be the slow inhibitory currents that have been shown to develop over several seconds in the cricket's auditory afferent pathway [23].

The natural acoustics did not cause very significant distortion of the sound pattern. Indeed it probably compares favorably with previous indoor environments where echoes from room walls could cause problems. It would be interesting to see whether this would change significantly if the ears were closer to the ground, and also what effects might be caused by different wind conditions. The main contributor of noise to the signal was the robot's own motors. Cricket's ears are actually on their forelegs, and it has been shown that during walking, there is substantial interference in the neural encoding of calling songs [25]. Typically, crickets will stop quite frequently during auditory tracking, although

this depends on several other factors such as the light level. However, it has also been shown that they are capable of tracking in an experimental paradigm where sound is switched off whenever they stop moving [33], so stopping cannot be their only strategy for dealing with self-induced noise. It is possible that they may use some kind of filtering for predictable sounds.

A further issue raised is what processing is needed beyond the simple "sound is on this side" response of the brain neurons (BN1 and BN2) to get an effective and coordinated response. The system needs to produce a turn signal of size and duration that will effectively alter the heading of the robot, and this is highly dependent on the robot morphology, e.g. it differs substantially for the Koala and for Whegs ASP, and is likely to differ again for a robot with independently controlled, multi-segmented legs. Similarly, it seems likely that more subtle modulation of the forward speed needs to occur. Current models of insect walking control [5], [16] suggest that the details of legged locomotion (gait, posture, stance, swing, reflex adjustments to load, etc.) can be encapsulated in "motor control circuitry" that only requires a simple velocity vector (speed and direction) as input from the higher-level brain mechanism guiding the animal. However, for effective robot-specific tracking, we are still faced with the issue of how continuous and smoothly modulated speed and direction outputs can be derived from the inherently intermittent cricket song signal.

Acknowledgments

This research was supported by EPSRC grant GR/M77239 and by NSF/IGERT grant DGE-9972747. Robert MacGregor at the University of Edinburgh designed and built the tether boxes and robot interface circuitry. Thanks also to Darren Smith for help in running the outdoor experiments.

References

- [1] Ayers, J. (2002). A conservative biomimetic control architecture for autonomous underwater robots. in J. Ayers, J. Davis, & J. Rudolph (editors), *Neurotechnology for Biomimetic Robots*. Cambridge, MA: MIT Press.
- [2] Bachmann, R.J., Kingsley, D.A., Quinn, R.D., Ritzmann, R.D. (2002), A Cockroach Robot with Artificial Muscles. Proceedings of Climbing and Walking Robots Conference (CLAWAR02), Paris, France.
- [3] Birch, M.C., Quinn, R.D., Hahm, G., Phillips, S.M., Drennan, B.T., Fife, A.J., Beer, R.D., Yu, X., Garverick, G., Laksanacharoen, S., Pollack, A.J., Ritzmann, R.E., (2002) "A Miniature Hybrid Robot Propelled by Legs," *IEEE Robotic & Automation*

- Magazine*, Vol. 10, Dec. 2002.
- [4] Birch, M.C., Quinn, R.D., Ritzmann, R.E., Pollack, A.J., Philips, S.M. (2002). Micro-robots inspired by crickets. Proceedings of Climbing and Walking Robots Conference (CLAWAR'02), Paris, France.
- [5] Espenschied, K. S., Quinn, R. D., Chiel, H. J., and Beer, R. D., (1996) Biologically-based distributed control and local reflexes improve rough terrain locomotion in a hexapod robot. *Robotics and Autonomous Systems*, 18, pp 59-64.
- [6] Franceschini, N., Pichon, J. M., and Blanes, C. (1992). From insect vision to robot vision. *Philosophical Transactions of the Royal Society B*, 337, 283-294.
- [7] Grasso, F., Consi, T., Mountain, D., and Atema, J. (2000). Biomimetic robot lobster performs chemo-orientation in turbulence using a pair of spatially separated sensors: Progress and challenges. *Robotics and Autonomous Systems*, 30(1-2), 115-131.
- [8] Hedwig (2002). Personal communication.
- [9] Jindrich, D.L. and R.J. Full (1999). Many-legged maneuverability: dynamics of turning in hexapods. *J.exp. Biol.* 202, pp. 1603-1623.
- [10] K-Team (1996). *Khepera User Manual*. Lausanne: EPFL.
- [11] K-Team (1996). *Koala User Manual*. Lausanne: EPFL.
- [12] Lambrinos, D., Moller, R., Labhart, T., Pfeifer, R., and Wehner, R. (2000). A mobile robot employing insect strategies for navigation. *Robotics and Autonomous Systems*, 30(1-2), 39-64.
- [13] Lund, H. H., Webb, B., and Hallam, J. (1998). Physical and temporal scaling considerations in a robot model of cricket calling song preference. *Artificial Life*, 4(1), 95-107.
- [14] Michelsen, A., Popov, A. V., and Lewis, B. (1994). Physics of directional hearing in the cricket *Gryllus bimaculatus*. *Journal of Comparative Physiology A*, 175, 153-164.
- [15] Morrey, J.M., Horchler, A.D., Didona, N., Lambrecht, B., Ritzmann, R.E. and Quinn, R.D. (submitted) Increasing Small Robot Mobility Via Biological Inspiration, 2003 IEEE International Conference on Robotics and Automation (ICRA'03) Video Proceedings, Taiwan.
- [16] Nelson, G. M. and Quinn, R. D., "Posture Control of a Cockroach-like Robot," IEEE Control Systems, Vol. 19, No. 2, April 1999.
- [17] Pollack, G. S. (1998). Neural Processing of Acoustic Signals. in R. R. Hoy, A. N. Popper, & R. R. Fay (editors), *Comparative Hearing: Insects* (pp. 139-196). New York: Berlin: Springer.
- [18] Quinn, R.D., Kingsley, D.A., Offi, J.T. and Ritzmann, R.E., (2002), Improved Mobility Through Abstracted Biological Principles, IEEE Int. Conf. On Intelligent Robots and Systems (IROS'02), Lausanne, Switzerland.
- [19] Quinn, R.D. Nelson, G.M., Bachmann, R.J., Kingsley, D.A., Offi, J. and Ritzmann, R. E. (2001). Insect designs for improved robot mobility. Proceedings of 4th Int. Conf. On Climbing and Walking Robots (CLAWAR), From Biology to Industrial Applications, edited by K. Berns and R. Dillmann, Professional Engineering Publishing, pp. 69-76.
- [20] Reeve, R. and Indiveri, G. (2001). A neuromorphic robot. Proceedings of the Neuromorphic Engineering Workshop, Telluride.
- [21] Reeve, R. and Webb, B. (2002). New neural circuits for robot phonotaxis. *EPSRC/BBSRC International Workshop Biologically-Inspired Robotics: The Legacy of W. Grey Walter* Hewlett-Packard.
- [22] Ritzmann, R.E., R.D. Quinn, J.T. Watson, S.N. Zill (2000) Insect walking and biorobotics: A relationship with mutual benefits. *Bioscience*, Vol. 50, No. 1, Jan. 2000.
- [23] Römer, H. and Krusch, M. (2000) A gain control mechanism for processing of chorus sounds in the afferent auditory pathway of the bushcricket *Tettigonia viridissima* (Orthoptera: Tettigoniidae) *Journal of Comparative Physiology A*, 186, 181-191.
- [24] Saranli, U., Buehler, M. and Koditschek, D. (2001). RHex a simple and highly mobile hexapod robot. *Int. J. Robotics Research*, 20(7): 616-631.
- [25] Schildberger, K., Milde, J.J. and Horner, M. (1988) The function of auditory neurons in cricket phonotaxis II Modulation of auditory responses during locomotion. *Journal of Comparative Physiology A*, 163, 633-640
- [26] Srinivasan, M. V., and Venkatesh, S. (1997). *From Living Eyes to Seeing Machines*. Oxford: Oxford University Press.
- [27] Watson, J.T., Ritzmann, R.E. (1998) "Leg kinematics and muscle activity during treadmill running in the cockroach, *Blaberus discoidalis*: I. Slow running," *J. Comp. Physiology*, Vol. 182: 11-22.
- [28] Watson, J.T., Ritzmann, R.E., Zill, S.N., Pollack, A.J. (2002) "Control of obstacle climbing in the cockroach, *Blaberus discoidalis*: I. Kinematics," *J. Comp. Physiology* Vol. 188: 39-53.
- [29] Webb, B. (1995). Using robots to model animals: a cricket test. *Robotics and Autonomous Systems*, 16, 117-134.
- [30] Webb, B. (2001). Can robots make good models of biological behaviour? *Behavioural and Brain Sciences*, 24(6), 1033-1094.
- [31] Webb, B., and Harrison, R. R. (2000). Integrating sensorimotor systems in a robot model of cricket behavior. *Sensor fusion and Decentralised Control in Robotic Systems III*. Boston Nov 6-8: SPIE.
- [32] Webb, B., and Scutt, T. (2000). A simple latency dependent spiking neuron model of cricket phonotaxis. *Biological Cybernetics*, 82 (3), 247-269.
- [33] Weber, T., Thomson, J., and Huber, F. (1981). Auditory behavior of the cricket I: Dynamics of compensated walking. *Journal of Comparative Physiology A* 141:215-232.