

COURTESY OF THE ASIA SOCIETY/COLLECTION OF THE ARTIST

Heri Dono
Ceremony of the Soul,
1995.

Randall D. Beer, Roger D. Quinn, Hillel J. Chiel,
and Roy E. Ritzmann

Biologically Inspired Approaches to Robotics

What can we learn from insects?

WHEN IT COMES TO AUTONOMOUS ROBOTS, THE CONTRAST between fantasy and reality is really quite striking. On the one hand, we have the fantasy of such anthropomorphic robots as C3PO from *Star Wars* and Commander Data from *Star Trek: The Next Generation* which, despite their endearing quirks, negotiate complex physical and social environments with essentially the skill of a human being. On the other hand, we have the reality of industrial robots that can efficiently carry out such highly specialized tasks as painting and welding only in environments carefully constrained to minimize complications. Or, to consider a second example, we have Dante II, the semi-autonomous robot that had to be lifted out of a volcano it was exploring with a crane when it overturned. Far from being

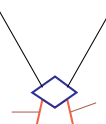
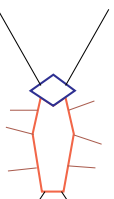

a limitation unique to the Dante II project, which should be applauded for confronting such a difficult environment, this brittleness in the face of unanticipated contingency is in fact typical of the state of the art in autonomous robotics.

BY CONTRAST, AN INSECT CAN'T DEPEND ON A crane to lift it out of a dangerous situation when it loses a leg. Instead, when an insect loses a leg, it immediately adopts a different gait more appropriate to the new configuration. While most robots are designed to either avoid much of the actual complexity of the real world or to minimize its impact, animals evolved to thrive under these conditions, and they often depend upon or even actively exploit this complexity in their behavior. And they do this with a relatively slow and noisy collection of nerve cells that, at first glance, would seem to be no match for even the slowest modern microprocessor. Yet even the lowly cockroach can outperform the most sophisticated autonomous robot at nearly every turn. What can we learn from biology?

For the past nine years, first in simulation and more recently in actual robots, we have been exploring this very question in the context of legged robots whose design and control are directly based on studies of insect walking and its neural basis. We've found walking to be an excellent vehicle for exploring biologically inspired approaches to robotics. Walking is a technically challenging problem with a wide range of obvious applications, from extraterrestrial exploration to surveillance and reconnaissance to dangerous industrial tasks. Unfortunately, the performance of current legged robots, which typically involve either teleoperation or centralized planning and control algorithms that are computationally intensive and brittle, are very limited on natural terrain. In contrast, the performance of even simpler legged animals such as insects is truly remarkable. In this article, we review our efforts to incorporate some of the principles of walking in animals into the design and control of legged robots. A general historical overview of research in legged robotics can be found in Chapter 14 in [4]. For a recent review of work on biologically inspired approaches to walking, see [7].¹

From Biology to Robotics

What does it mean for something to be “biologi-

¹Other recent work in this area includes Brooks (1989); Cruse et al. (1995); Donner (1987); Ferrell (1995); Pfeiffer et al. (1994); Raibert (1986)—contact Randall Beer (beer@alpha.ces.cwru.edu) for more detailed reference information.

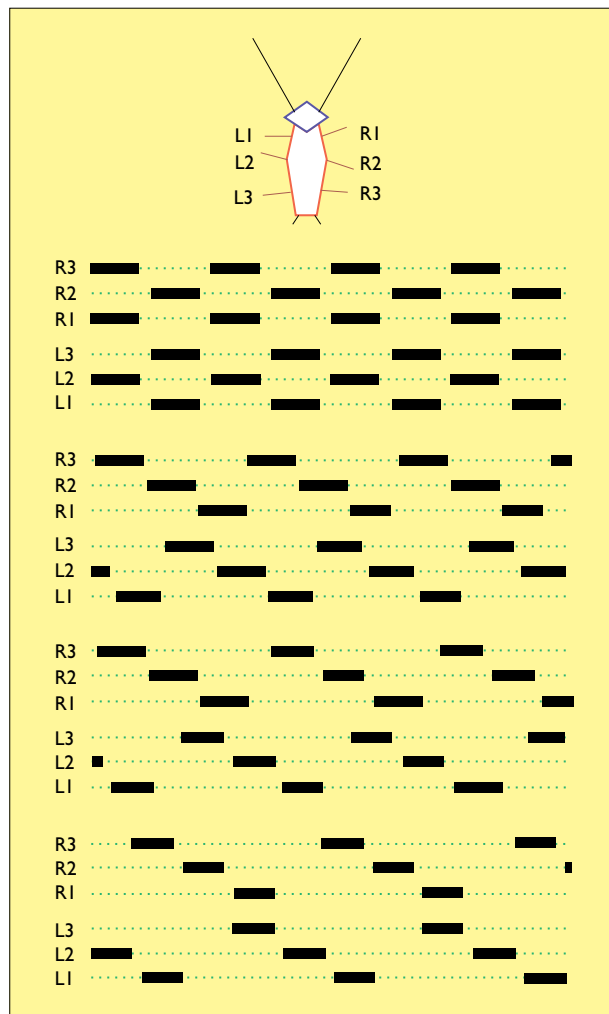

Figure 1. A selection of insect-like gaits. Black bars represent the swing phase of a leg and the space between bars represents its stance phase. The leg labeling conventions are shown at top.

cally inspired?” Many different degrees of inspiration are possible, from vague resemblance to strict emulation. Consider robot locomotion. At the simplest extreme of biological inspiration, we could emulate only the trivial observation that animals use legs rather than wheels, or the observation that the use of six legs by insects provides them with particularly stable support. At the other extreme, we could literally try to emulate, in every detail, a particular species of insect.

Between these two extremes, a wide range of intermediate positions are possible. For example, one could:

- Use studies of the number and configuration of the leg degrees of freedom that insects utilize in crossing rough terrain, and the patterns of torque that these degrees of freedom develop, to select the best leg geometry for a robot.

- Examine in detail the types of sensory information that insects use to fine-tune their leg movements.
- Attempt to emulate the different behavioral strategies that insects use to traverse different kinds of terrain.
- Attempt to base the design of walking controllers for legged robots on the organizational and architectural principles of the neural circuitry underlying insect walking.

WE TEND TO ERR BY INCLUDING MORE biology than may at first appear to be strictly necessary. The reason for this strategy is straightforward: it almost always pays off. While nature's way may not be the only way, or even necessarily the best way, time and again we have found unexpected benefits to paying close attention to the design of biological systems. Thus, our work draws directly from biological literature and we closely integrate experimental studies of animal behavior and physiology with robot design and construction. In order to facilitate this close interaction between biological experimentation and robotic engineering, we have focused our efforts on invertebrates such as insects. Unlike their popular image as simple automatons controlled by unsophisticated reflexes, invertebrates thrive in a truly remarkable range of environments, and they exhibit a rich variety of complex behaviors, including highly skilled motor behavior, learning and memory, communication, and cooperative behavior. Indeed, invertebrates provide direct analogues for nearly all of the capabilities that we would like an autonomous robot to possess. Despite this complexity, detailed study of invertebrate behavior and its underlying neural control is often far more technically feasible than it is for vertebrates.

At the same time, biological inspiration is not biological modeling, and the goals of an engineering project are not the same as those of a scientific project. Ultimately, an engineering project must be judged by the extent to which it creates useful artifacts, while a scientific project must be judged by the extent to which it illuminates and explains some natural phenomenon. While we firmly believe that designing robots can illuminate and even test questions of biological relevance, the work described here is unabashedly engineering. The bottom line is the extent to which our particular approach results in devices whose performance exceeds that achieved by existing approaches.

Distributed Gait Control

Insects walk with a variety of different patterns of leg movements or gaits at different speeds of locomotion. In insects, these gaits typically have the property of static stability, that is, the polygon of support formed by connecting all of the supporting legs always contains the center of mass of the body. The movement of each leg can be divided into a stance phase, in which a leg is providing support and propelling the body, and a swing phase, in which the leg is lifted from the ground and swinging forward in order to begin another stance phase. Given the fundamental importance of the relative timing of swing phases (since a swinging leg provides no support to the body), the different gaits observed in insects can be described by displaying the times at which each leg swings (Figure 1). Insect gaits range from the wave gait at slow speeds of walking, in which only one leg swings at a time, to the tripod gait at high walking speeds, in which the front and back legs on each side of the body step in unison with the middle leg on the opposite side. Note that all insect gaits are characterized by a stepping sequence known as a metachronal wave, in which sequences of swings propagate from the back of the insect to the front on each side of the body.

One of the key characteristics of locomotion control in animals is distribution. Rather than concentrating responsibility for locomotion in one centralized system, animals distribute this responsibility across the physical characteristics of the legs themselves, endogenous and reflexive circuitry local to each leg, and additional circuitry that interconnects these local leg controllers. Rather than having a single module directing the movements of the legs in a master/slave fashion, in a distributed locomotion controller stable gaits arise from the cooperative interactions between many different components. Such a distributed approach can significantly decrease the computational demands placed on each component of the locomotion system, and lends flexibility and robustness to the overall behavior.

A Distributed Neural Network Controller

In 1988, as part of a larger project aimed at simulating the neural control of a variety of insect behaviors, we designed a distributed neural controller for hexapod walking [2] based on studies of the neural basis of cockroach walking [11]. This circuit is shown in Figure 2. Each leg is controlled by a local circuit consisting of a pacemaker neuron (P), two sensory neurons that signal when the leg has reached an extreme forward (FAS) or backward (BAS) angle, and three motor neurons responsible for controlling the state of

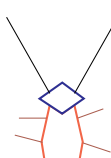
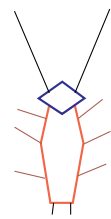

the foot (FT), and the rate with which the leg swings forward (FS) and backward (BS). In addition, all leg controllers receive identical excitation from a command neuron (C) and the pacemaker neurons of adjacent leg controllers mutually inhibit one another. Each of these model neurons is a leaky integrator whose integrated inputs are passed through a piecewise linear activation function with a threshold and a saturation.

Each pacemaker neuron also possesses a pair of intrinsic currents that cause it to burst rhythmically. The burst frequency depends linearly on the overall level of excitation that the pacemaker receives, and strong transient inputs can reset the burst pattern.

EACH LEG-CONTROL circuit operates in the following manner. Normally, the foot motor neuron is active and excitation from the command neuron activates the backward swing motor neuron, producing a stance phase. However, periodic bursts of activity from the pacemaker neuron inhibit the foot and backward swing motor neurons and excite the forward swing motor neuron, producing a swing phase. Pacemaker bursts are fine-tuned by sensory feedback from the angle sensors. In addition, direct connections from the forward angle sensor to the motor neurons duplicates a reflex that has been described in the cockroach. The command neuron sets the overall speed of locomotion by controlling both the frequency of pacemaker bursts and the rate with which the leg swings backward during stance.

The leg-control circuit described in the preceding paragraph is capable of producing the basic swing

and stance movements required by each leg. However, in order to successfully walk, these individual leg movements must also be properly coordinated so as to maintain static stability. This is accomplished by two mechanisms. First, inhibitory connections between the pacemaker neurons of adjacent leg controllers discourage adjacent legs from stepping at the same time. These connections alone are sufficient for

producing the tripod gait at high speeds of walking. At lower speeds, a mechanism is required for producing metachronal waves. This was accomplished by slightly lowering the natural frequency of the rear legs, so that the rear pacemakers entrain the middle and front pacemakers in a metachronal sequence.

Simulations demonstrated that this circuit could produce a continuous range of statically stable hexapod gaits in a way that was remarkably resistant to damage [2]. In order to test the performance of this circuit in the real world, we built our first hexapod robot in 1991 (Figure 3). Each of the robot's six legs had two degrees of freedom: they could swing back and forth relative to the body and they could extend or retract along their length. Each of these motions was produced by a two-watt DC motor. The

position of each joint was sensed by a potentiometer. The entire robot measured 50cm long by 30cm wide, and weighed approximately 1kg. The neural circuit described previously was simulated in real time on a 386-compatible PC. Signals from the potentiometers were thresholded and input to the forward and backward angle sensors. The outputs of the forward and backward motor neurons were integrated to produce a trajectory of joint positions that

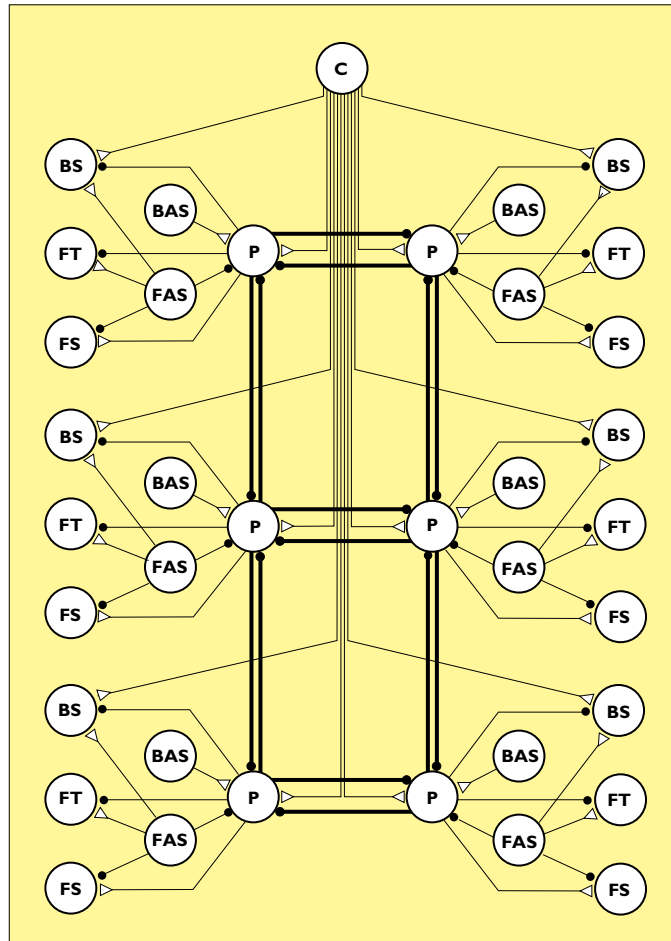

Figure 2. Schematic diagram of a distributed neural network for the control of locomotion. Excitatory connections are denoted by open triangles and inhibitory connections are denoted by filled circles.

Abbreviations: C, command neuron; P, pacemaker neuron; FT, foot motor neuron; FS and BS, forward swing and backward swing motor neurons; FAS and BAS, forward and backward angle sensors.

was tracked using proportional feedback position control to lend a springlike compliance to the robot's locomotion.

Using this robot, we were able to reproduce all of

based on the positions of the other legs [6]. In our robotic implementation of these mechanisms, each leg moves at a constant speed during the swing phase, while the speed at which a leg moves during

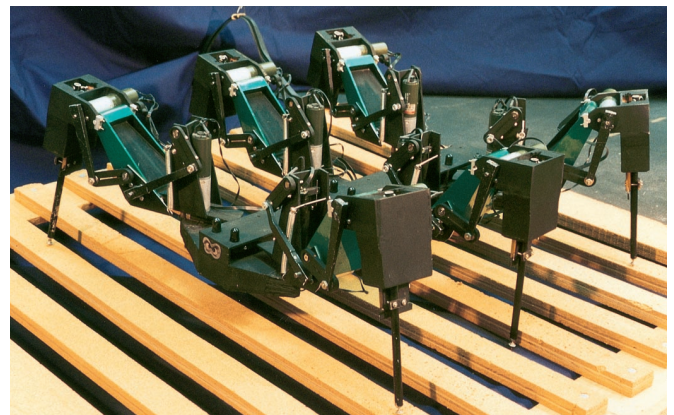
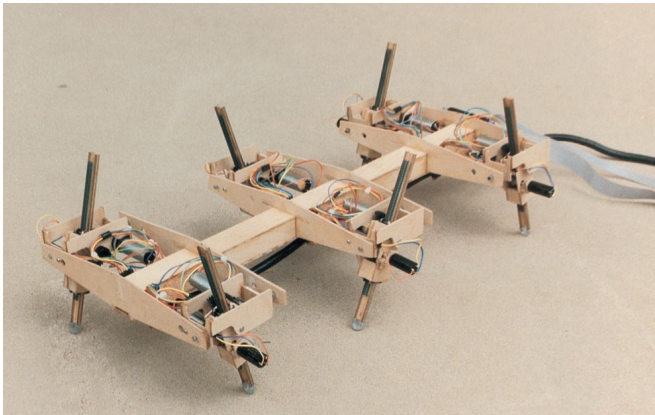

Figure 3. (left) Robot I (right) Robot II

the results observed in our earlier simulations. As the activity of the command neuron in the simulated neural circuit varied, the robot exhibited the full range of gaits seen in simulation at speeds ranging from 4.5cm/sec to 8.3cm/sec (Figure 1)—see [1] and Chapter 16 in [4]. As the command neuron's activity was varied, this entire range of gaits falls out of the interactions between the local leg controllers. In addition, smooth changes in gait and speed could be produced by smoothly varying the activity of the command neuron. Furthermore, we were able to demonstrate that this circuit's ability to generate statically stable gaits was strikingly resistant to damage, including the loss of a single sensor or the loss of a fraction of the inhibitory connections between pacemakers [5]. These results demonstrate that control principles abstracted from animals can indeed lead to effective, efficient, and robust controllers for robots.

A Stick Insect Controller

Work on the mechanisms that coordinate walking in the stick insect provided a second example of a distributed approach to gait control. In 1992, we set out to explore the application of these mechanisms to the control of our first robot [8].

Leg coordination in the stick insect is achieved by several kinematic mechanisms that adjust the position at which each leg is lifted and swung forward

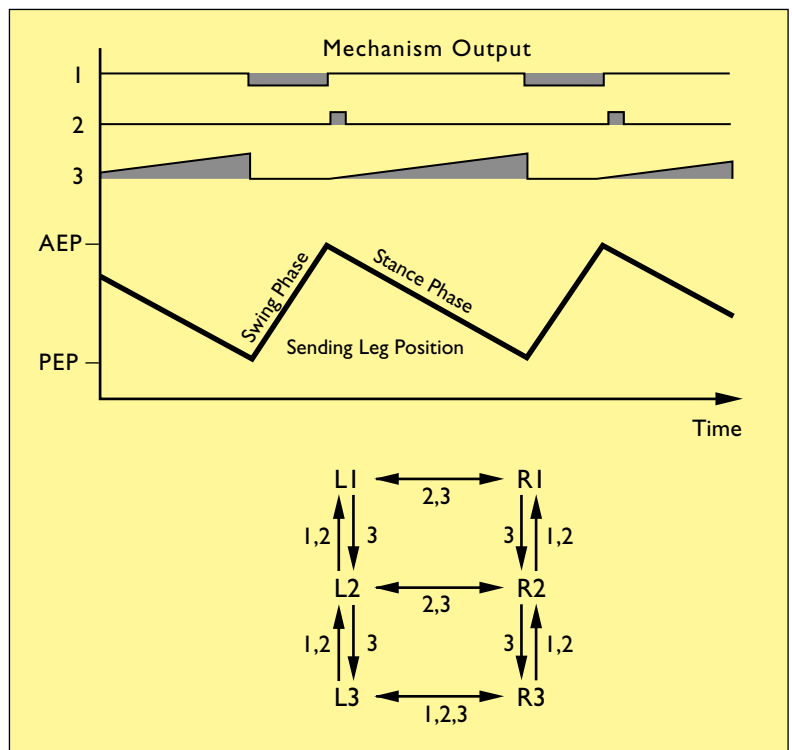
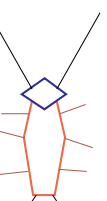
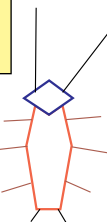

Figure 4. Stick insect gait-coordination mechanisms. The position of one leg over time and the outputs of the three coordination mechanisms of that leg are shown at top. Abbreviations: AEP, anterior extreme position; PEP, posterior extreme position. The layout of these three mechanisms between each pair of legs is shown at bottom.

the stance phase is proportional to a single user input. When a stancing leg reaches an extreme posterior position (PEP), it is lifted and swung forward. When a swinging leg reaches an extreme anterior



position (AEP), it is put down and a new stance phase is begun. The coordinating influences operate by having the position of one leg modify the PEP of another leg.

Three major influences have been described in the stick insect (Figure 4, top). In the first mechanism, a swinging leg discourages another leg from swinging by shifting the PEP of that leg backward

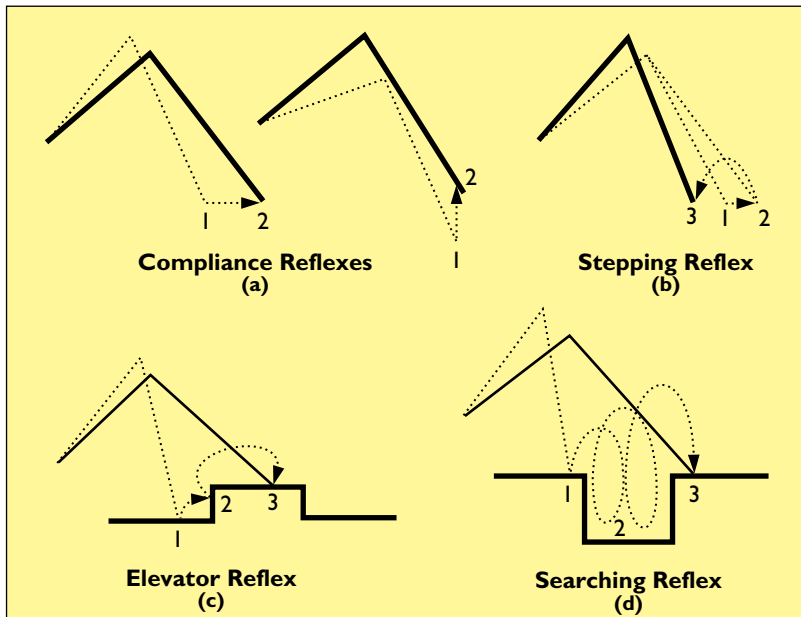

Figure 5. Leg reflexes implemented in the second robot

a small amount. In the second mechanism, a leg that has just begun its stance briefly encourages another leg to swing by shifting the PEP of that leg forward by a small amount. In the third mechanism, a stancing leg increasingly encourages another leg to swing by shifting the PEP of that leg forward by an increasing amount. These various mechanisms operate between pairs of adjacent legs as shown at the bottom of Figure 4. The PEP of each leg is continuously updated based on the sum of the interleg influences that it receives at each moment.

USING THIS DISTRIBUTED NETWORK OF COORDINATION mechanisms, our robot could walk with a wider range of statically stable hexapod gaits at a wider range of speeds than was observed in our first controller. These gaits ranged from the wave gait at slow speeds of walking (< 3cm/sec) to the tripod gait at high speeds of walking (14cm/sec). In addition, smooth changes in gait and speed could be elicited by varying the input speed. As in the neural circuit described previously, this range of gaits arises

from the interactions between the various local mechanisms rather than from any centralized gait generator. Also like the neural circuit described earlier, the stick insect coordination mechanisms were quite robust to damage. The controller could produce effective locomotion despite the removal of any single interleg influence.

Evolved Locomotion Controllers

A third approach to the distributed control of walking was explored in our first robot. This approach was also biologically inspired, but in a different sense than the two controllers described previously. Rather than basing the design of a locomotion controller on a particular animal, we instead attempted to mimic the process by which biological controllers are designed. Specifically, in 1991 we used a genetic algorithm to evolve dynamical neural networks for controlling the locomotion of a simulated insect [3]. By manipulating the reliability of leg-angle sensors, we were able to control the extent to which the evolved locomotion circuits relied on sensory feedback.

Subsequently, an evolved circuit that was capable of generating a basic walking pattern in the absence of sensory feedback, but which also could use sensory feedback (when available) to improve its performance, was successfully applied to our first robot [10].

Rough Terrain Locomotion

OUR FIRST ROBOT ALLOWED US TO EXPLORE several different biologically inspired approaches to the design of distributed, robust, and computationally inexpensive controllers for the generation of statically-stable gaits for a hexapod robot. However, insects do much more than merely walk across flat horizontal surfaces with a variety of gaits at different speeds. What makes legs so appealing to roboticists is the remarkable ability of legged animals to traverse complicated natural terrains, which are often not level, may be slippery, provide poor support, have significant vertical variations, large obstacles, and provide sparse footholds—see Chapter 14 in [4]. Our goal for our second robot (Figure 3), completed in 1994, was to extend our biologically inspired approach to more natural terrain [7, 9].

In order to cope with the irregularity of natural

terrain, a more sophisticated mechanical design than that used in our first robot was necessary. The overall geometry of our second robot is loosely based on the stick insect, with its body suspended from its legs so as to enhance stability. Each leg has four independent degrees of freedom: three active revolute joints (two at the “hip” and one at the “knee”) and one passive spring-loaded linear joint. The active joints were driven by six-watt DC motors. The positions of the revolute joints are sensed by potentiometers, and each linear joint contains a strain gauge for sensing the load borne by that leg. The entire robot measures approximately 50cm long by 35cm wide and weighs approximately 5kg. The control system for this robot runs in real time on a 486-compatible PC.

An extension of the stick insect gait controller described previously was used to produce the basic walking movements for this robot. The major modification involved generalizing the one-dimensional movement between AEP and PEP to two-dimensional leg movement, so that a leg switches state whenever it passes outside of a two-dimensional region. This allows the robot to walk in a straight line with the familiar range of gaits at speeds up to 14cm/sec, and also to walk along curved paths, to turn in place, and to walk sideways. The same distributed mechanisms enforce the proper coordination of the legs in all of these cases.

Walking across complicated terrain requires more than simply generating statically stable gaits, and insects utilize a variety of strategies and reflexes to cope with this complexity [12]. Several of these were incorporated into our second robot:

- A combination of passive and active compliance is used to maintain a stable posture on complex terrain (Figure 5a). Passive compliance arises from the springs in the linear joints of each leg. Active compliance arises from (a) spring-like proportional feedback position control at each revolute joint; (b) reduction of joint stiffness in response to increased loads; (c) distribution of vertical load among the supporting legs. These compliance mechanisms allow the robot to stably conform to terrain containing height disparities as large as 25cm.
- Mechanisms already described endow the robot with a stepping reflex that allows the robot to compensate for any mechanical perturbations that it receives while walking on rough terrain. Due to the compliance mechanisms, lateral perturbations will initially be resisted and then complied with as the force increases. When the

disturbance is removed, the robot will return to its desired posture. In addition, the gait control mechanisms ensure that any leg that is sufficiently perturbed will step to a more posturally favorable position (Figure 5b). These mechanisms also allow the robot to continue to make progress even if one of its legs is mechanically prevented from unloading and is moved with the robot, so that it never swings forward.

- An elevator reflex allows the robot to cope with vertical obstructions (Figure 5c). If a swinging leg encounters an obstacle, it is briefly retracted and lifted higher before continuing its swing. Especially high obstacles can trigger this reflex multiple times during a single swing.
- If no footholds are available at the end of swing phase or if support is lost in a stancing leg, a searching reflex is triggered (Figure 5d). This reflex produces a sequence of oscillatory movements biased in the direction of movement that grow in amplitude with each cycle. Using this reflex, the robot can traverse slatted surfaces on which less than 50% of the surface area provides support.

By combining the distributed gait control mechanisms with the various local leg reflexes described previously, the robot can generate relatively smooth locomotion over extremely irregular terrain. For example, the robot can successfully traverse a large piece of styrofoam packing material at a speed of 2cm/sec. This material has a peak-to-peak amplitude of 11cm and major features occur at a frequency of approximately six per meter. In addition, styrofoam is light and compliant, so that it moves and deforms as the robot traverses it. The compliance mechanisms allow the robot to adjust its posture to the irregularities of the styrofoam. The elevator reflex allows individual legs to clear vertical protrusions. The searching reflex allows the robot to find stable footholds among the holes. Thus, a relatively computationally inexpensive and biologically inspired gait controller, coupled with a variety of simple local reflexes found in insects, can produce smooth locomotion over complicated terrain without any global knowledge of terrain characteristics.

Conclusion

This article has surveyed our efforts over the past nine years to incorporate some of the principles of insect walking into the design and control of legged robots. This work has highlighted the robotic applications of several general principles of insect walking, including:

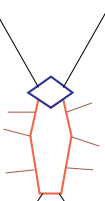
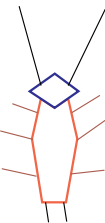

- Highly distributed control;
- Synergistic combination of local reflexes with distributed gait control;
- Matching the mechanical properties of the body to the demands of the terrain and the design of the controller.

The application of these principles to the design and control of legged robots has resulted in devices that can effectively move over complex terrain with only very modest computational resources using highly distributed control systems that are very robust. We are currently at work on our third robot, a cockroach-like hexapod in which we hope to explore the mechanics of climbing and running, as well as the use of antennae to adjust leg movements to approaching obstacles in a predictive fashion. In support of this new robot, we are currently engaged in detailed studies of the leg movements and muscle activations made by cockroaches negotiating a variety of obstacles. In addition, we are working with the robotics company K²T, Inc. of Duquesne, Pennsylvania, to apply these principles to the control of a prototype robot for finding and either collecting or destroying both land and underwater mines.

Yet we have barely scratched the surface of what mere insects have to teach us about the design and control of legged robots. Insect legs have many more degrees of freedom than current legged robots, including both flexible segments and claws that allow them to grip unstable surfaces and to walk along steep inclines or even on inverted surfaces. In addition, gram for gram, muscle is a far more powerful and efficient actuator than the best electric motors currently available. Furthermore, insect legs are populated with hundreds of sensors that provide far more information about the positions, velocities, and accelerations of each joint and the stresses experienced by each segment than current legged robots have access to. Antennae, which are also densely populated with a variety of sensory structures, are also used by insects to adjust their leg movements to the terrain ahead. Most importantly of all, insect nervous systems integrate this vast collection of sensory feedback to flexibly reconfigure the many available degrees of freedom on a step-by-step basis, producing steady locomotion under an amazingly diverse set of conditions. Until we have legged robots that can travel over natural terrain with the skill of an insect traversing the forest floor, we would do well to pay close attention to the lessons that these “simple” animals have yet to teach us. 

REFERENCES

1. Beer, R.D., Chiel, H.J., Quinn, R.D., Espenschied, K. and Larsson, P. A distributed neural network architecture for hexapod robot locomotion. *Neural Computation* 4, 3 (1992), 356–365.
2. Beer, R.D., Chiel, H.J. and Sterling, L.S. Heterogeneous neural networks for adaptive behavior in dynamic environments. In *Neural Information Processing Systems 1*, D.S. Touretzky, Ed. Morgan Kaufman, 1989, 577–585.
3. Beer, R.D. and Gallagher, J.G. Evolving dynamical neural networks for adaptive behavior. *Adaptive Behavior* 1 (1992), 92–122.
4. Beer, R.D., Ritzmann, R.E., and McKenna, T., Eds. *Biological Neural Networks in Invertebrate Neuroethology and Robotics*. Academic Press, San Diego, 1993.
5. Chiel, H.J., Beer, R.D., Quinn, R.D., and Espenschied, K. Robustness of a distributed neural network controller for a hexapod robot. *IEEE Trans. Robotics and Automation* 8, 3 (1992), 293–303.
6. Cruse, H. What mechanisms coordinate leg movement in walking arthropods? *Trends in Neuroscience* 13 (1990), 15–21.
7. Espenschied, K.S., Quinn, R.D., Beer, R.D. and Chiel, H.J. Biologically-based distributed control and local reflexes improve rough terrain locomotion in a hexapod robot. *Robotics and Autonomous Systems* 18 (1996), 59–64.
8. Espenschied, K.S., Quinn, R.D., Chiel, H.J. and Beer, R.D. Leg coordination mechanisms in stick insect applied to hexapod robot locomotion. *Adaptive Behavior* 1, 4 (1993), 455–468.
9. Espenschied, K.S., Quinn, R.D., Chiel, H.J. and Beer, R.D. Biologically-inspired hexapod robot control. In *Proceedings of the Fifth International Symposium on Robotics and Manufacturing* (Maui, Hawaii, Aug. 14–18,), 1994.
10. Gallagher, J.G., Beer, R.D., Espenschied, K. and Quinn, R.D. Application of evolved locomotion controllers to a hexapod robot. *Robotics and Autonomous Systems* (in press).
11. Pearson, K.G. The control of walking. *Scientific American* 235 (1976), 72–86.
12. Pearson, K.G. and Franklin, R. Characteristics of leg movements and patterns of coordination in locusts walking on rough terrain. *International J. Robotics Research* 3 (1984), 101–112.

RANDALL D. BEER (beer@alpha.ces.cwru.edu) is an associate professor in the Department of Computer Engineering and Science and in the Department of Biology at Case Western Reserve University. <http://yugoth.ces.cwru.edu/beer/beer.html>
ROGER D. QUINN (rdq@po.cwru.edu) is an associate professor in the Department of Mechanical and Aerospace Engineering at Case Western Reserve University.

HILLEL J. CHIEL (hjc@po.cwru.edu) is an associate professor in the Department of Biology and in the Department of Neuroscience at Case Western Reserve University.

ROY E. RITZMANN (rer3@po.cwru.edu) is a professor in the Department of Biology and in the Department of Neuroscience at Case Western Reserve University.

This work was supported in part by grant N00014-90-J-1545 from the Office of Naval Research and by grant NGT-50588 from the NASA Goddard Space Flight Center. Additional support was provided by the Cleveland Advanced Manufacturing Program through the Center for Automation and Intelligent Systems Research at CWRU and the Howard Hughes Medical Institute. The original version of this material was prepared while Randall Beer was on a sabbatical leave at the Santa Fe Institute, whose support throughout this time is gratefully acknowledged.

Permission to make digital/hard copy of part or all of this work for personal or classroom use is granted without fee provided that copies are not made or distributed for profit or commercial advantage, the copyright notice, the title of the publication and its date appear, and notice is given that copying is by permission of ACM, Inc. To copy otherwise, to republish, to post on servers, or to redistribute to lists requires prior specific permission and/or a fee.
